



FEROGLIDE

Self lubricating bearings

General Information



FEROGLIDE self lubricating bearings

FEROGLIDE bearings are low friction, self lubricating, and have high load carrying capabilities. They are made up of a woven PTFE layer bonded to a metal support. The metal backing is chosen to be suitable for the application and is usually chosen from mild steel, zinc plated mild steel, stainless steel, Inconel, brass or bronze.

FEROGLIDE bearings are available in a range of shapes and sizes (see TENMAT Ltd Size leaflet).

FEROGLIDE liners can also be bonded to customer supplied components.

FEROGLIDE PA1

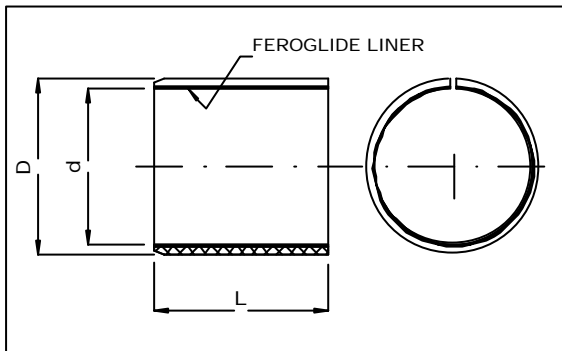

FEROGLIDE PA3

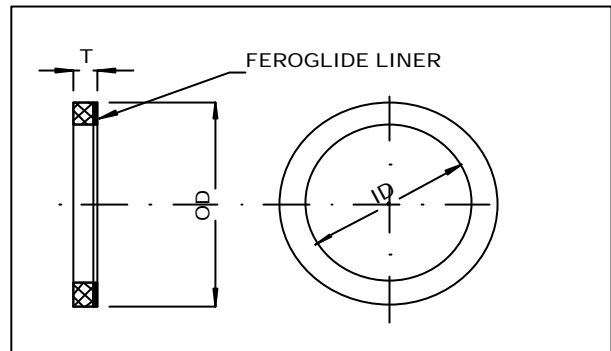

FEROGLIDE PA7

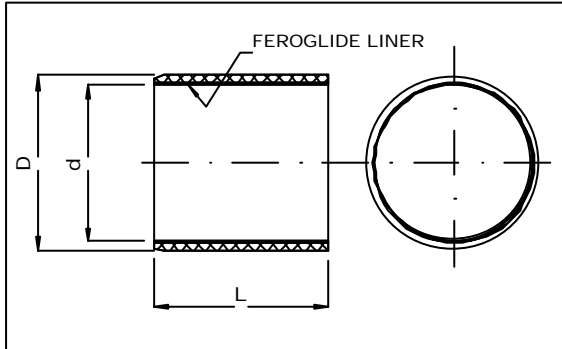

FEROGLIDE PC3

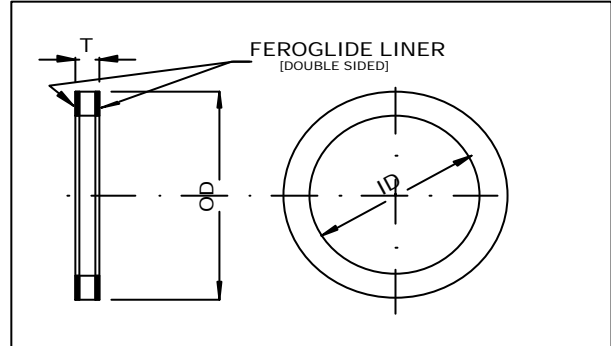

FEROGLIDE PA8

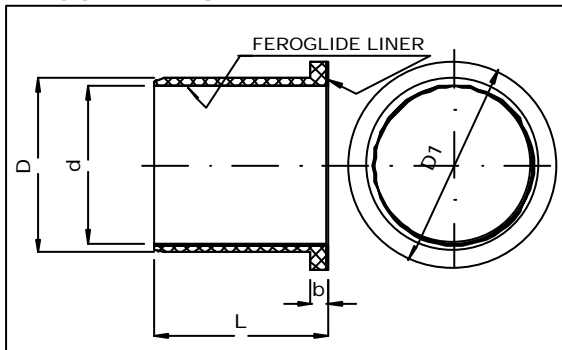

GLIDE STRIPS

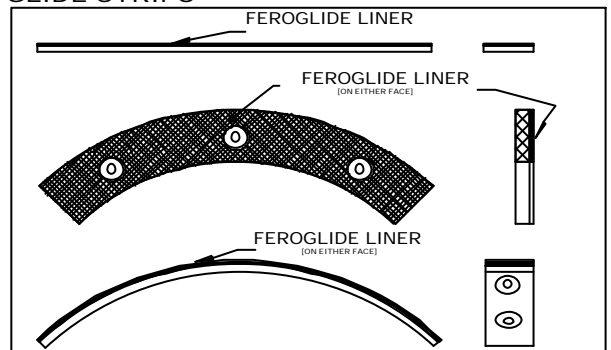

Applications

FEROGLIDE bearings are used to allow movement between mating surfaces in many different industries, for example:

Valves: FEROGLIDE bearings are used in all types of valves and are typically used for trunion bearings and stem guides.

Hydro power plants: FEROGLIDE bearings are ideally suited for turbine guide vane assemblies and their actuators accomodating the high surface pressures involved.

Agricultural machinery: In farm tractor kingpin, rocker shaft and hitch assemblies.

Crane and lifting equipment: Crane and hoist manufacturers use FEROGLIDE bearings' ability to handle very high loads in boomfoot pivots, and hinge and brace points in the mast pendant assembly which are inaccessible for grease lubrication.

FEROGLIDE bearings are completely self lubricating and normally run dry, however they can also be used where lubricating or other fluids are present. In dry operation, FEROGLIDE bearings are recommended where low surface speeds are combined with high loads (see Technical Manual).

FEROGLIDE Features and Benefits

FEROGLIDE bearings:

- ✍ Are self lubricating and operate without external lubrication.
- ✍ Are free from stick slip, giving easy movement and operation.
- ✍ Are composite in nature and do not have the cold flow tendencies of solid and filled PTFE resins.
- ✍ Have high wear resistance giving long life.
- ✍ Can operate at temperatures beyond the range of most lubricants -50C to +150C.
- ✍ Are corrosion resistant so can be used with aggeasive liquids such as sea water, gasoline, acids, detergent solutions, hydraulic oils, ammonium hydroxide, oils.
- ✍ Are strong and can carry loads up to 420 N/mm² for stainless steel and Inconel.
- ✍ Have good dimensional stability and the capacity to be formed to close tolerances.

Comparison of FEROGLIDE with other materials

	FEROGLIDE	Filled PTFE	Nylon	Sintered Bronze
Maximum static load N/mm ²	420	17	7	60
Temperature range C	-50 to 150	-200 to 250	-20 to 90	-20 to 250
Maximum speed (m/min)	10	3	1.5	450
Chemical resistance	Excellent	Excellent	Fair	Fair
Minimum coefficient of friction	0.02	0.02	0.25	0.5

FEROGLIDE - Construction

FEROGLIDE is a propriety self lubricating bearing material of woven PTFE fibres applied to a rigid backing. To assure the best possible bond between the PTFE fibres and backing material, a secondary more readily bondable fibre is interwoven with the PTFE fibres so that Teflon is predominantly presented on the bearings side of the fabric.

FEROGLIDE bearings have the ability to resist PTFE cold flow under extremely high loads because the monofilament fibres have a tensile strength approximately 15 times greater than straight PTFE resins. Cold flow is also minimised by the effective entrapment of the fibre bundles by the high strength bonding resins.

The metal backing is chosen to be suitable for the application and is usually chosen from mild steel, zinc plated mild steel, stainless steel, Inconel, brass or bronze.

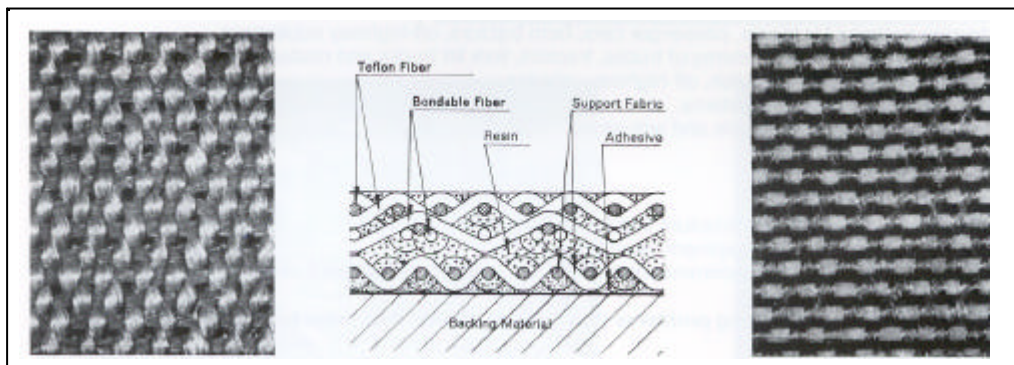

Under the microscope, the bearing side of FEROGLIDE liner presents only PTFE fibers.

FEROGLIDE Material Cross Section
(Teflon is a Trademark of Du Pont)

Secondary and more readily bondable fiber (showing white) is interwoven with the PTFE on the bonding side

Typical problems that prompt the use of FEROGLIDE bearings.

- ✍ Lubricant films are unable to be maintained.
- ✍ Lubricants are unacceptable or undesirable because of contamination.
- ✍ Non lubricating fluids are difficult to exclude from the bearing area.
- ✍ High static impact loads are encountered.
- ✍ Fretting corrosion occurs with conventional bearings.
- ✍ Freedom from stick slip is a desirable feature.
- ✍ Oscillating or sliding movements are involved.
- ✍ Conditions of high load with relatively low speeds are encountered.
- ✍ Corrosive substances are present.
- ✍ Unusual temperature conditions prevail.
- ✍ Distortion problems create misalignment.
- ✍ Maintenance cost reduction is important.